

# **INSTALLATION AND USER MANUAL**

## **MagnaPure 22/28mm Duo Magnetic Filter**

Thank you for choosing Buy It Direct.  
Please read this user manual before using this  
valve and keep it safe for future reference.

# Contents

SAFETY WARNINGS.....	3
COMPONENTS.....	3
ASSEMBLY INSTRUCTIONS.....	4
PRODUCT OVERVIEW.....	5
WHAT'S IN THE BOX.....	5
SAFETY INFORMATION.....	5
INSTALLATION.....	5
MOUNTING RECOMMENDATIONS.....	6
STRUCTURE INTRODUCTION.....	8
INSTALLATION METHOD.....	8
WATER TREATMENT & ADDITIVES.....	10
TROUBLESHOOTING.....	10
ANNUAL SERVICING REQUIREMENT.....	11
CHEMICAL DOSING.....	11
TECHNICAL SPECIFICATION.....	12
UK SUPPORT.....	12
SERVICING CHECKLIST.....	13

# SAFETY WARNINGS

For your continued safety, please follow all the safety precautions listed below at all times.:

- This device is designed for residential use.
- Keep small parts and packaging out of reach of children to avoid choking hazards.
- Dispose of packaging and keep safe any extra parts, to ensure children and pets do not swallow.
- Take care when the heating is on as the metal parts will be hot to the touch.
- Install the device securely according to the manual.
- Installation should be carried out by a qualified professional or other fully competent person.
- Ensure all components are present. Report any missing or damaged parts to your supplier immediately.

# COMPONENTS

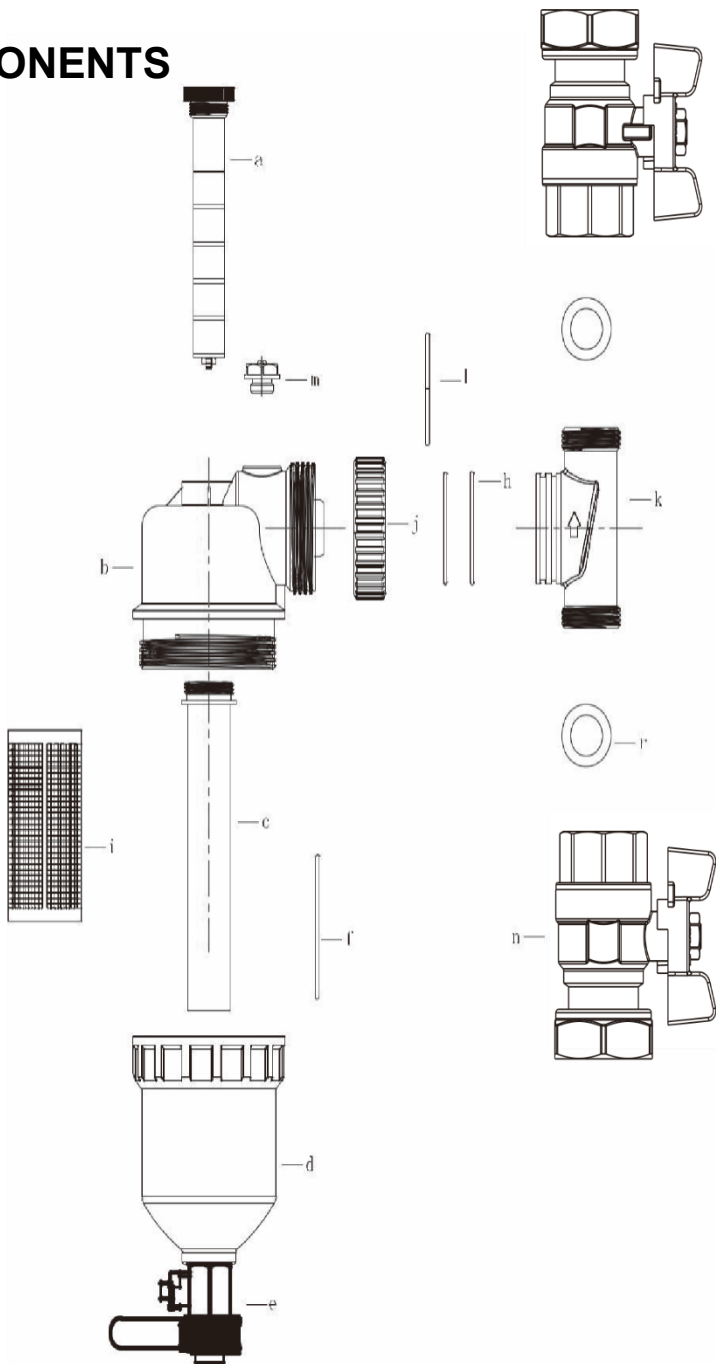

Ref	Description
<b>a</b>	Magnetic core (bar)
<b>b</b>	Filter body
<b>c</b>	Cleaning cap
<b>d</b>	Canister lid
<b>e</b>	Drain-off valve
<b>f</b>	O-ring (seal)
<b>g</b>	Colour cap
<b>h</b>	O-ring (secondary)
<b>i</b>	Internal mesh filter
<b>k</b>	Rotating joint
<b>l</b>	Snap ring
<b>m</b>	Air vent
<b>n</b>	Isolation valve (1")
<b>r</b>	Shim

# ASSEMBLY INSTRUCTIONS

Only a competent person, such as a qualified heating engineer, should install the device.

1. Locate a suitable site for the filter to allow access for servicing. The return pipe is recommended. Do not install between the boiler and the overflow on open-vented systems.
2. Release and drain the heating system pressure.
3. Mark the pipe using a suitable tool, then cut out the marked section and remove burrs.
4. Fit the isolating valves provided onto both inlet and outlet pipes.
5. Introduce the diverter, ensuring the arrow direction follows the heating system flow. Fit the diverter using the provided flat washers and tighten the inner nuts fully. Then tighten the outer compression nuts on the valves to ensure a watertight seal.
6. Fit the filter body to the diverter with sufficient strength and hand-tighten the locking collar (do not overtighten). The filter body must be installed vertically. The magnetic bar is removable.
7. Open the isolation valves and turn on the heating system.
8. Vent as required using the Top Air Bleed Valve.

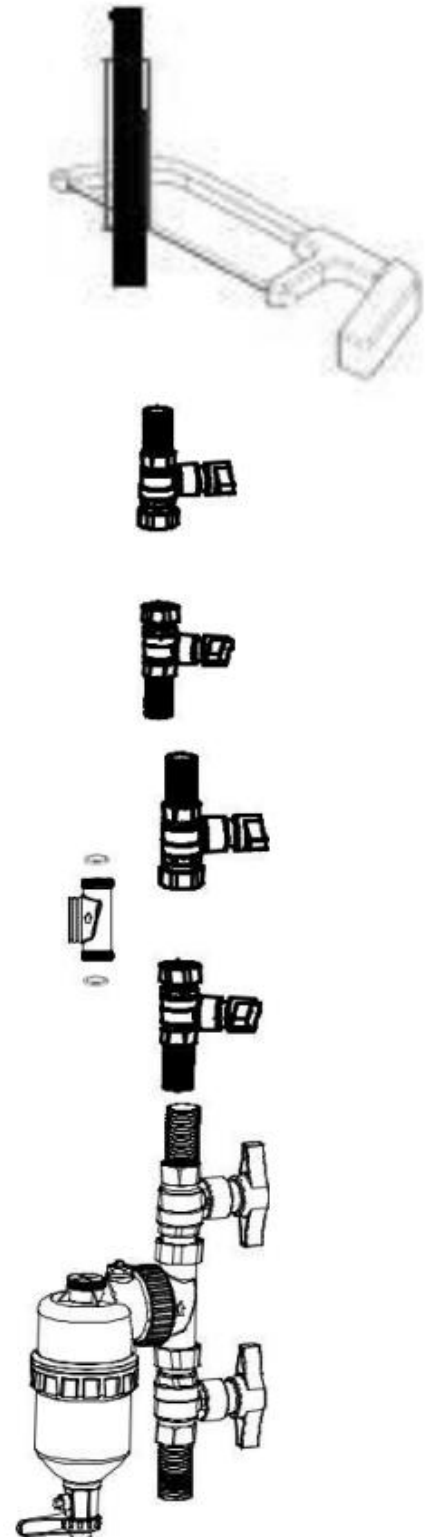

## PRODUCT OVERVIEW

The 22/28mm Duo Magnetic Filter captures magnetite and other ferrous debris, protecting boilers, pumps, and heat exchangers. For optimal performance, install on the return line. Includes full-bore flat-face chrome isolation valves: 28mm valves with 22mm reducers for versatile pipe compatibility.

## WHAT'S IN THE BOX

- MagnaPure filter body
- Two isolation valves
- Bleed screw and drain plug
- Servicing tool
- 28mm-22mm reducers
- User manual

## SAFETY INFORMATION

- Improper installation may result in device malfunction or damage to your radiator system.
- If you are uncertain about installation, consult a qualified technician. Avoid dropping the device, which may result in internal damage.
- Installation by qualified personnel only.
- Isolate and depressurise system before servicing.
- Allow the system to cool below 50°C
- Strong magnet: keep away from pacemakers and sensitive devices.
- Use PPE when handling sludge or chemicals.
- Do not exceed max pressure or temperature.
- Suitable for closed-loop heating and heat pump systems. Not for potable water.
- Ensure there is a water-filling pipeline behind the filter.
- During maintenance, inspect the lid seals for wear or damage. Best practice is to replace the lid seal during each repair.

## INSTALLATION

- Please ensure a competent person or qualified professional installs the MagnaPure filter and any required pipework connections.
- Turn the water off from the main valve.
- Bleed or isolate the radiator system to ensure no debris will flow into the pipes.
- Install the filter as per instructions bellow
- Turn the water back on from the main valve.
- Repressurise the system, leaving the air vent open on the new radiator to ensure it fills with water. Check for leaks.

## MOUNTING RECOMMENDATIONS

The filter can be installed in various positions along the main pipeline. For optimal protection and efficiency, it is recommended to install the filter on the primary return pipework, after the last radiator and before the boiler.

**⚠ Note: It is important to have adequate access for maintenance and servicing when determining a suitable installation location.**

### Recommended installation location

- **Combination/Sealed System**

The filter is placed on the primary return pipework after the last radiator and before the boiler, which is the recommended position for maximum protection and efficiency. The green check marks indicate correct positions, and the red cross shows an incorrect location (on the flow side).

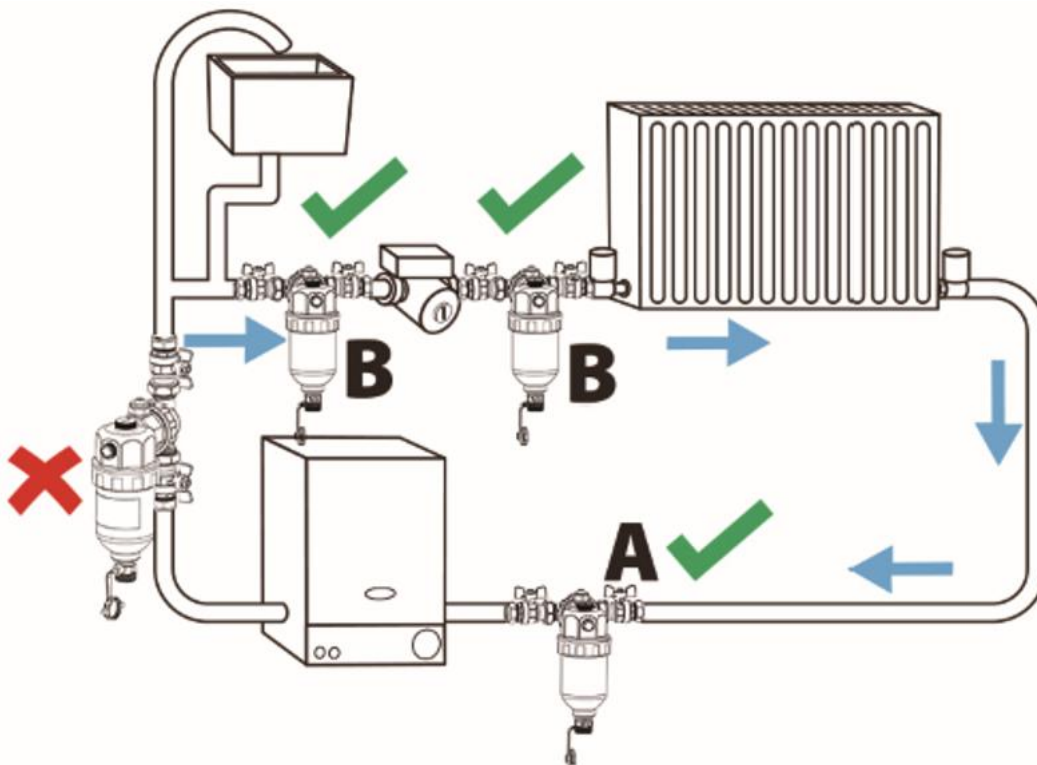

- **Open Vented System**

The filter is also installed on the return pipe before the boiler, which is correct. The green checks confirm suitable positions.

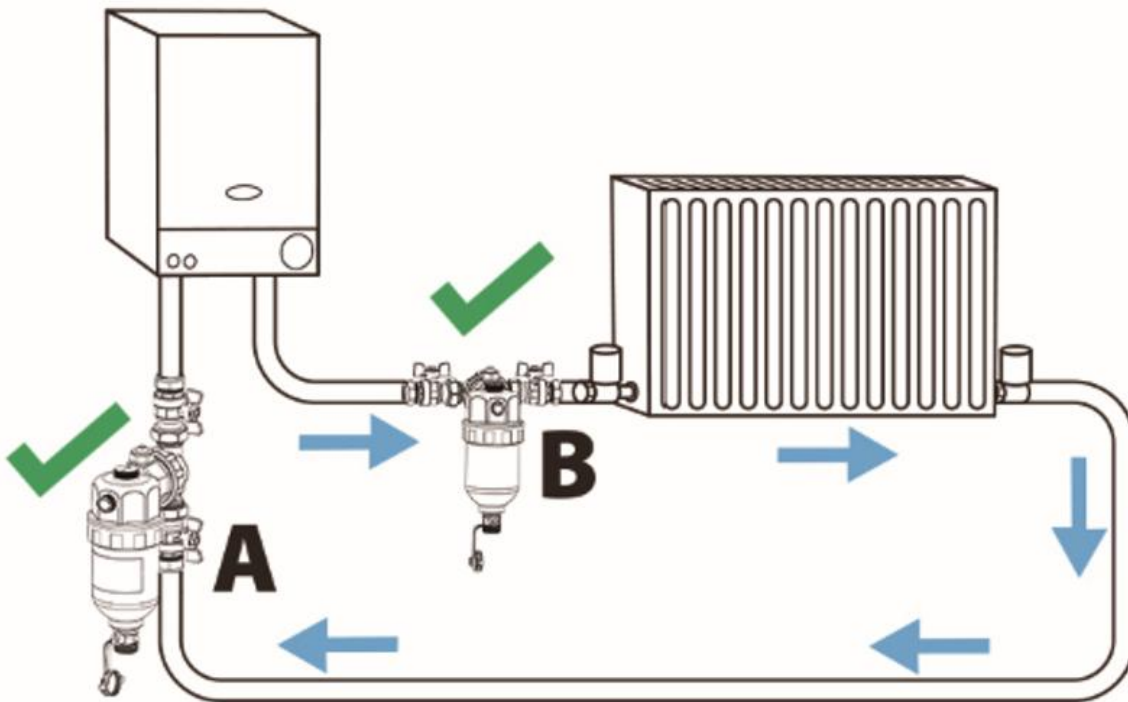

- **Heat pump systems, the principle is similar to boilers**

The magnetic filter should be installed on the return line before the heat pump unit, ideally after the last emitter (radiator or underfloor loop) and before the heat pump.

This ensures sludge and debris are captured before entering the heat exchanger, which is critical because heat pumps have narrow waterways that can clog easily.

**Additional considerations for heat pumps:**

Always ensure adequate inhibitors and biocides are added to prevent corrosion and bacterial growth, especially in low-temperature systems.

**Best practice:**

Return pipe → Magnetic filter → Heat pump → Flow pipe

## STRUCTURE INTRODUCTION

1. Air vent
2. Magnet bar
3. Drain valve
4. Inlet valve
5. Outlet valve

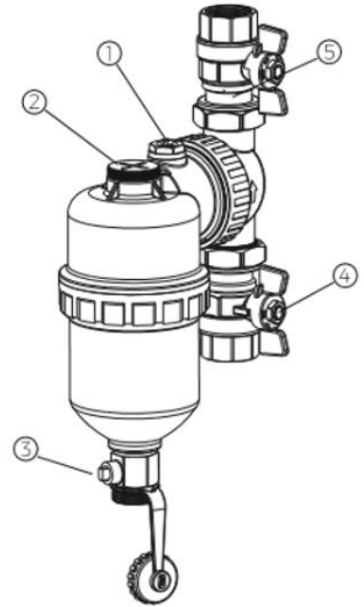

## INSTALLATION METHOD

1. Cut and remove the section of pipe according to the product's installation length.
2. Install the valves onto the pipework. Hand-tighten initially, then securely tighten the valves to the pipe.
3. Install the filter housing and tighten it.
4. Adjust the angle and secure the filter.
5. Ensure the valves are open. Allow the system to fill, then vent the filter through the air vent valve. Close the valve when complete.

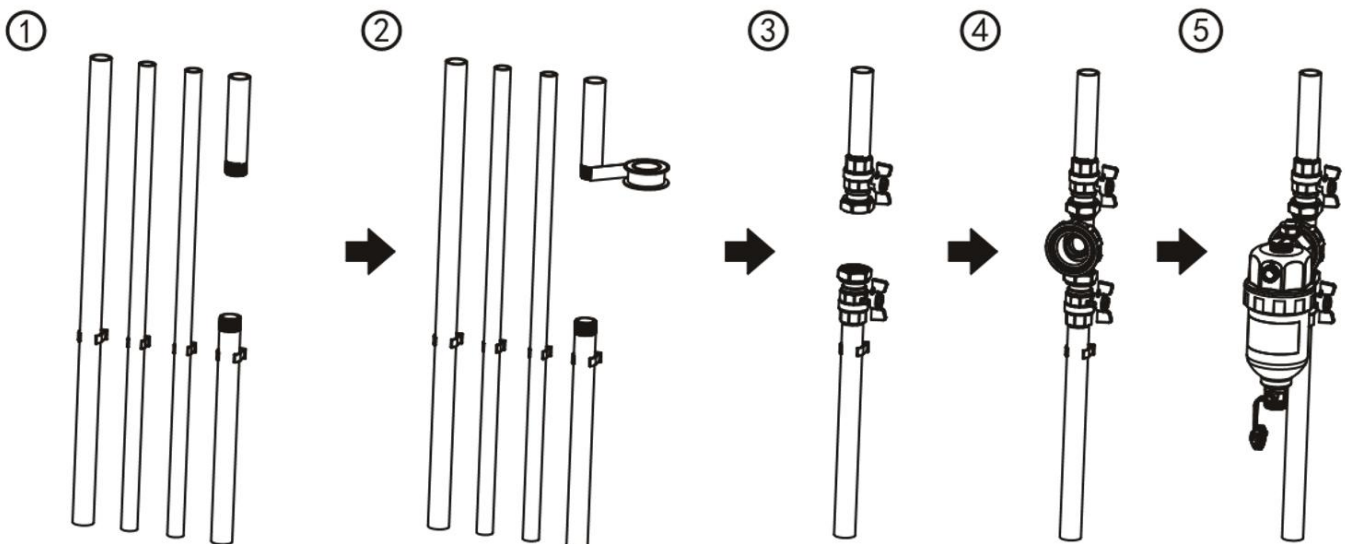



# MAINTENANCE AND SERVICING

**⚠ Note: Before carrying out any maintenance work, isolate the electrical supply to the boiler and allow the water to cool to a safe working temperature.**

1. Close both isolation valves.
2. Open the drain valve and place a bucket or similar receptacle underneath to collect debris. Remove the magnetic bar and store it in a safe place.
3. Open the inlet valve to flush out debris. Once all debris has been removed, introduce a suitable chemical inhibitor into the system. We recommend using an inhibitor. Refit the magnetic bar.
4. Open the inlet and outlet valves. Vent the filter through the air vent valve and close it when complete. Check for any leaks.
5. Complete all relevant documentation, e.g., dates and inhibitor used.

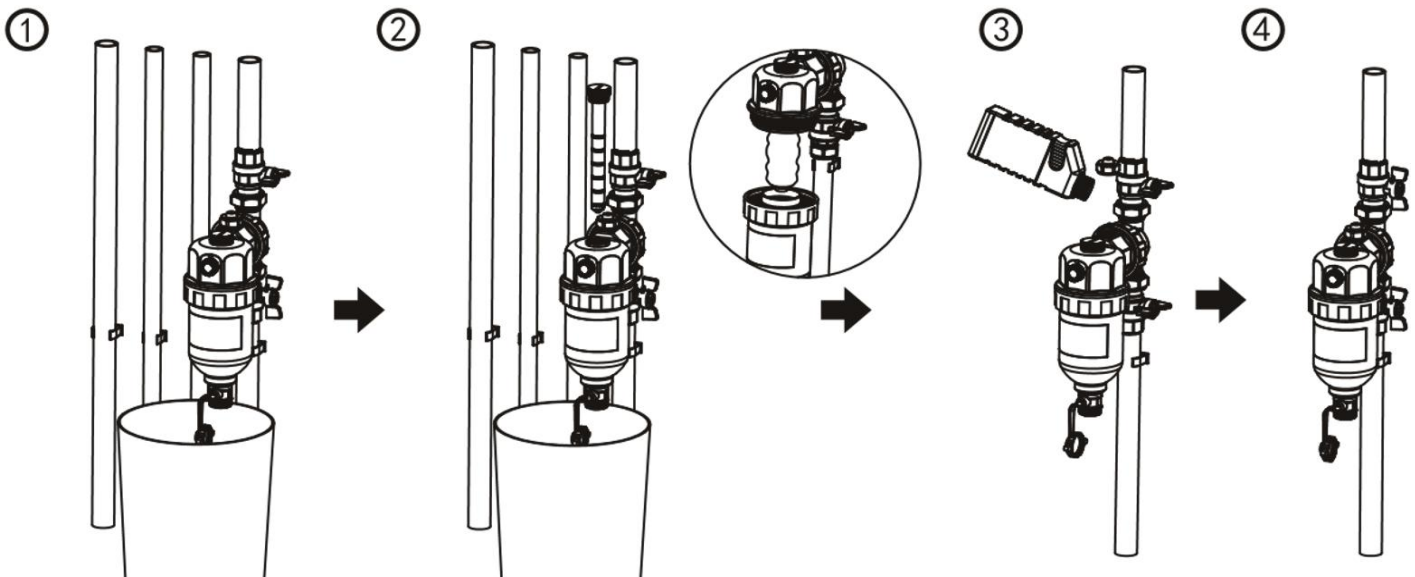

Maximum working pressure: 6 bar  
Flow rate: <50 l/min

Maximum operating temperature: 95 °C  
Direction of flow: follow the arrow

1. The magnetic filter contains powerful magnets. Keep it away from all electronic devices, bank cards, and other magnetic-sensitive items.
  
2. The magnetic filter should always be handled with caution, especially around devices such as pacemakers.
  
3. The magnetic filter is a pressurised device. Release pressure before performing any maintenance.
  
4. The magnetic filter can become very hot during operation. Handle with care.
  
5. To maintain grounding continuity in accordance with current IEE regulations, install appropriate grounding cables on the pipe where necessary to bypass the product

## **WATER TREATMENT & ADDITIVES**

**Follow BS 7593:2019: Clean → Flush → Filter → Protect → Test.**

- Use corrosion inhibitor (e.g., Fernox F1, Sentinel X100).
- For heat pumps, use inhibited glycol and biocide.
- Test annually and re-dose as needed.

## **TROUBLESHOOTING**

<b>Problem</b>	<b>Solution</b>
Water leaking from the filter	Turn off the system and close the isolating valves. Perform the following checks: <ol style="list-style-type: none"> <li>a) Check all seals for location and condition.</li> <li>b) Check the isolating valve nuts to ensure they are fully tightened.</li> <li>c) Check the converter locking collar is firmly tightened and not cross-threaded.</li> </ol>
Poor flow through filter	Clean the filter when reduced flow is observed.

# ANNUAL SERVICING REQUIREMENT

**To maintain optimum efficiency, annual cleaning is recommended.**

1. Isolate the heating system and close both isolating valves. Prepare a suitable container to collect any spillage.
2. Loosen the connection between the diverter and filter body, then rotate the filter body 180°. Use a standard 1" thread nut spanner to unscrew and remove the filter cap.
3. Remove the magnetic shield and wash it with hot soapy water.
4. Remove the stainless-steel strainer and clean it thoroughly with water.
5. Rotate the filter body another 180° to drain any remaining dirty water into a container.
6. After cleaning, replace both the magnetic shield and stainless-steel strainer. Tighten the filter cap by hand. Rotate the filter body back to the correct position with the air bleed valve at the top. Fully tighten the diverter/filter body connection. Slightly open the inlet valve and the bleed valve until all air is removed. Close the bleed valve, then fully open both inlet and outlet valves and check for leaks.
7. Start the heating system.

**⚠ WARNING:** Follow all safety instructions provided in this document. This filter contains a strong magnet. Exercise care during installation and servicing. Do not place the magnetic core on any ferrous surfaces or near ferrous items.

## CHEMICAL DOSING

**To maintain optimum efficiency, annual cleaning is recommended.**

1. Isolate the boiler and close both isolating valves. Release air pressure by opening the Top Air Bleed Valve.
2. Drain the filter completely: rotate the filter 180°, remove the filter cap by loosening the nut between the diverter and filter body. Place a container to collect water and open the bleed valve. Once drained, close the bleed valve.
3. Add chemicals through the open filter top. When complete, hand-tighten the filter cap.
4. Rotate the filter body back to the correct position with the air bleed valve at the top. Tighten the diverter/filter body connection. Slightly open the inlet valve and bleed valve until all air is removed. Close the bleed valve, then fully open both inlet and outlet valves and check for leaks.
5. Turn on the heating system to flush and vent as required.

**ATTENTION:** Do not allow chemicals to remain static in the filter for long periods.

## TECHNICAL SPECIFICATION

Maximum working pressure	12 bar
Permissible differential pressure	1.5 bar
Maximum fluid temperature	120 °C
Flow	< 3 m <sup>3</sup> /h (< 50 L/min)
Pipe connections	22 mm/28mm compression ( ¾ /1 inch)
Ball Valve size	28 mm ( 1 inch)
Isolation valves	2 x 28mm with 22mm reducers
Dimensions	H 230 x 85 mm dia.
Water Content	0.554L
Magnet force	9000 gauss
Valve material	Brass alloy
Body material	Reinforced nylon PA66

## UK SUPPORT

Email: [customersupport@buyitdirect.co.uk](mailto:customersupport@buyitdirect.co.uk)  
Call: 0330 041 2271 or complete the online form  
Office hours: 9 AM - 5 PM, Monday to Friday

Unit 2A, Trident Business Park,  
Neptune Way, Leeds Road,  
Huddersfield, HD2 1UA.

# SERVICING CHECKLIST

- Isolate the valves
- Vent system pressure
- Remove the magnetic core
- Drain and clean the filter
- Inspect seals for wear or damage
- Reassemble and bleed the system
- Check for leaks and top up inhibitor

V20251111DDVS